

# XP95 INPUT/OUTPUT UNIT

## FUNCTION

The XP95 Input/Output Unit provides a voltage-free, single pole, change-over relay output, a single, monitored switch input and an unmonitored, non-polarised opto-coupled input.

## FEATURES

The Input/Output Unit supervises one or more normally-open switches connected to a single pair of cables. It is set to return an analogue value of 4 in the event of an open or short-circuit fault and 16 during normal operation. The status of the inputs is reported by means of two input bits.

The change-over contact is operated by an output bit.

## ELECTRICAL CONSIDERATIONS

The XP95 Input/Output Unit is loop powered and operates at 17–28V DC with protocol voltage pulses of 5–9V.

## PROTOCOL COMPATIBILITY

The unit will operate only with control equipment using the Apollo Series 90, XP95 or Discovery digital protocol.

## PROTOCOL BIT USAGE

*The control equipment transmits a 10-bit message to the Input/Output Unit:*

The **output (or forward command) bits** from the control panel have the following function:

**Output bits 2 and 1** are not used.



Part no 55000-818 (surface mount)

When **output bit 0** is set to logic 1 on two or more consecutive pollings, the relay changes state to the "set" condition. Bit 0 must be set to logic 1 as long as it is desired to keep the relay in its set state. The relay will remain latched in the set state until output bit 0 is set to logic 0 on two or more consecutive pollings. Neither the removal of loop power nor the discontinuation of interrogation of its address will affect the state – set or not – of the relay.

The relay will not change state during the first 30 seconds after application of loop power. If a command bit is received during this period, it will be actioned at the end of the 30 second period. If the device is not interrogated during this period, the relay will automatically reset.

© Copyright Apollo Fire Detectors Limited 1997–2005



36 Brookside Road, Havant, Hampshire PO9 1JR, England.

Tel: +44 (0)23 9249 2412 Fax: +44 (0)23 9249 2754 Website: [www.apollo-fire.co.uk](http://www.apollo-fire.co.uk) Email: [sales@apollo-fire.co.uk](mailto:sales@apollo-fire.co.uk)



INVESTOR IN PEOPLE



Assessed to ISO 9001: 2000  
Quality Systems Certificate number 010



After the 30 second period, ie, during normal operation, the relay changes state within 0.1 second of receipt of a command.

The **seven bits** which are then transmitted by the control panel correspond to the **address (as set on the DIL switch)** of the device to be polled.

*A response message is then sent by the Input/Output Unit to the control equipment:*

The **interrupt bit** is always set to logic "0"

The **analogue value bits** are set to return a pre-set analogue value of 4 during open or short-circuit faults and 16 when the switch is open or closed. Full details are shown in the table opposite.

The **input bits** have the following function:

**Input bit 2** is not used.

**Input bit 1** is used to report the status of the opto-coupled input. If the voltage on this input is less than 1V, input bit 1 is set to "0". If the input voltage is greater than 4V, input bit 1 is set to "1". At input voltages between 1 and 4V the input is indeterminate; input bit 1 may be either "0" or "1".

**Input bit 0** is used to report the status of the monitored switch input. During normal operation, ie, when the switch is open, and in the event of a fault (open or short-circuit), input bit 0 is set to "0". When the switch is closed, input bit 0 is set to "1". Details of input conditions are given in the table opposite.

The **type bits** are used to identify the type of unit responding. The type code of the Input/Output Unit is 010 00 (bits 2, 1, 0, 4, 3 respectively). Bits 2, 1 and 0 are sent immediately after the input bits and bits 4 and 3 are sent in the XP95 protocol extension.

The Input/Output Unit sends seven bits of data to confirm its **address** and then **one bit** to indicate that the device can use the XP95 protocol (**XP95 flag**).

The **alarm flag** is not placed by the Input/Output Unit.

The **parity bit** is set to "1" or "0" such that the device will always respond with an even number of data bits.

The **final seven bits** are the **alarm/interrupt address** and are not used by the Input/Output Unit.

## MECHANICAL CONSTRUCTION

The Input/Output Unit is normally supplied with a backbox for surface mounting. It is also available without the backbox for flush mounting. Both versions are designed for indoor use only.

Three LEDs, two red and one yellow, are visible through the front cover of the enclosure.

One red LED is illuminated to indicate that the relay is set. The second red LED is illuminated to indicate that the switch input is closed.

The yellow LED is illuminated whenever a fault condition (open or short circuit) has been detected.

The enclosure is moulded from the same white self-extinguishing polycarbonate as Apollo detectors.

## Dimensions and weight of Input/Output Unit (surface mount):

150 x 90 x 48mm      240g

## Input conditions and status

Resistance across input		Status	Analogue value	Input Bit		
				2	1	0
<100Ω		Short-circuit fault	4	0	†	0
100–200Ω		Indeterminate	4 or 16	0	†	0 or 1
200–11kΩ	4.7Ω	Switch closed	16	0	†	1
11–15kΩ		Indeterminate	16	0	†	0 or 1
15–25kΩ	20kΩ	Normal (switch open)	16	0	†	0
25–30kΩ		Indeterminate	4 or 16	0	†	0
>30kΩ		Open-circuit fault	4	0	†	0

The values in italics are recommended values. †See “input bit 1” opposite

## Technical data

Series 90/XP95 loop voltage	17–28V DC
Maximum current consumption at 24V	
switch-on surge, max 150ms	3.5mA
quiescent, 20kΩ EOL fitted	1.2mA
switch input s/c, max (LED on)	6mA
any other condition (max 2 LEDs on)	4.5mA
Switch input monitoring voltage (open-circuit condition)	9-11V DC
Maximum cable resistance	50Ω
Opto-coupled input voltage impedance	max 35V DC 10kΩ
Relay output contact rating at 30V AC or DC	max 1A (inductive or resistive)
Relay output wetting current at 10mV DC	10μA
Operating temperature	20°C to +70°C
Humidity (no condensation)	0–95%
Shock	
Vibration	
Impact	to EFGS/F/95/007
IP rating 54	
Radiated emissions	to BS EN 50081–1 & 2
Radiated immunity	to BS EN 50082–1



## Schematic Diagram and Wiring Connections

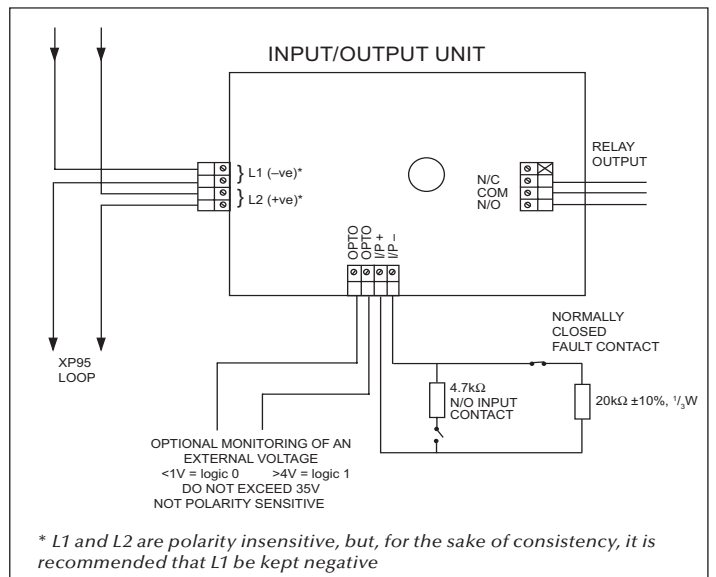

### LOW VOLTAGE DIRECTIVE 73/23/EEC

No electrical supply greater than 50V AC rms or 75V DC should be connected to any terminal of this Input/Output Unit.

### EMC DIRECTIVE 89/336/EEC

The XP95 Input/Output Unit complies with the essential requirements of the EMC directive 89/336/EEC, provided that it is used as described in this PIN sheet and that the contact is not operated more than five times a minute or twice in any two seconds.

A copy of the Declaration of Conformity is available from Apollo on request.

Conformity of the XP95 Input/Output Unit with the EMC directive does not confer compliance with the directive on any apparatus or systems connected to it.